

# HYDRAULIC HOIST

type 76363-200

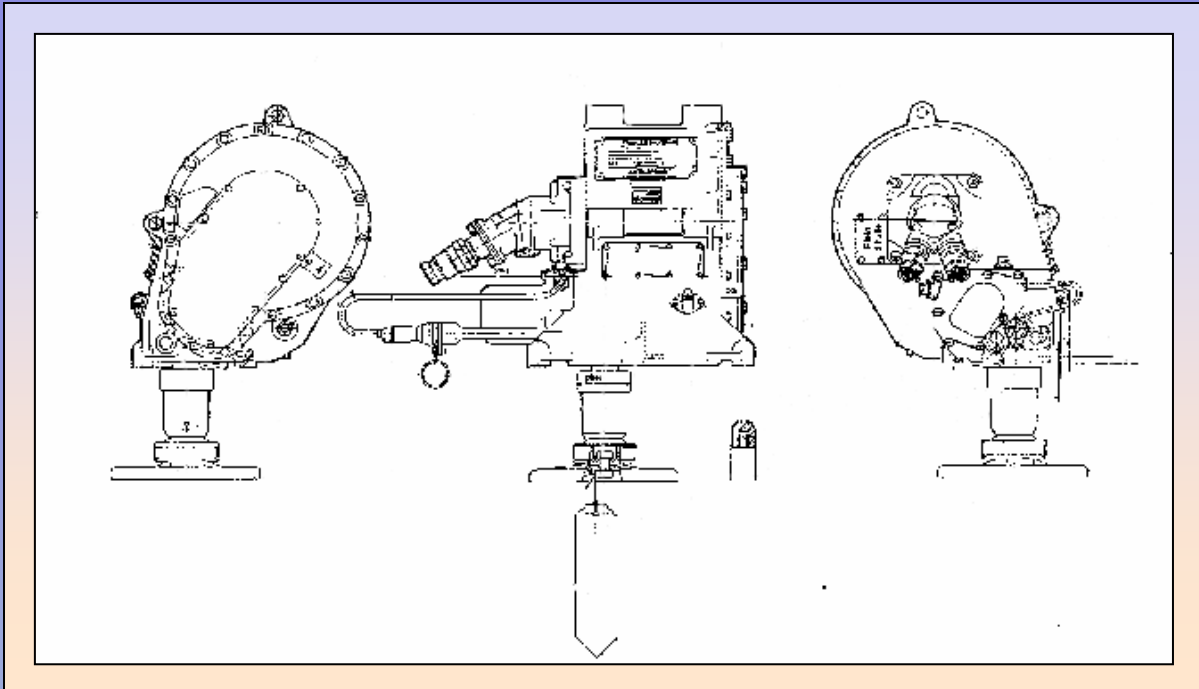

## MAIN CHARACTERISTICS

CAPACITY	Lb force	600
USABLE CABLE LENGTH	Ft	164
RATED SPEED	Ft/min	100
WEIGHT	Lb	71,6
DUTY CYCLE		<i>Unlimited</i>
ELECTRICAL CONTROL VOLTAGE	V.dc	27
HYDRAULIC POWER AT $\Delta P$	US gal/min P.S.I.	317 1960

### SAFETY FEATURES :

- ◆ Self clamping carbon brake
- ◆ Automatic end limit stops
- ◆ Cartridge operated emergency cable cutter protected against EMI
- ◆ Universal hook assembly